

Assembly instructions for Crank Table

1002800 - B



Support: 46 (0)472-26 16 00

E-mail: info@gbp.se

Web: www.gbp.se

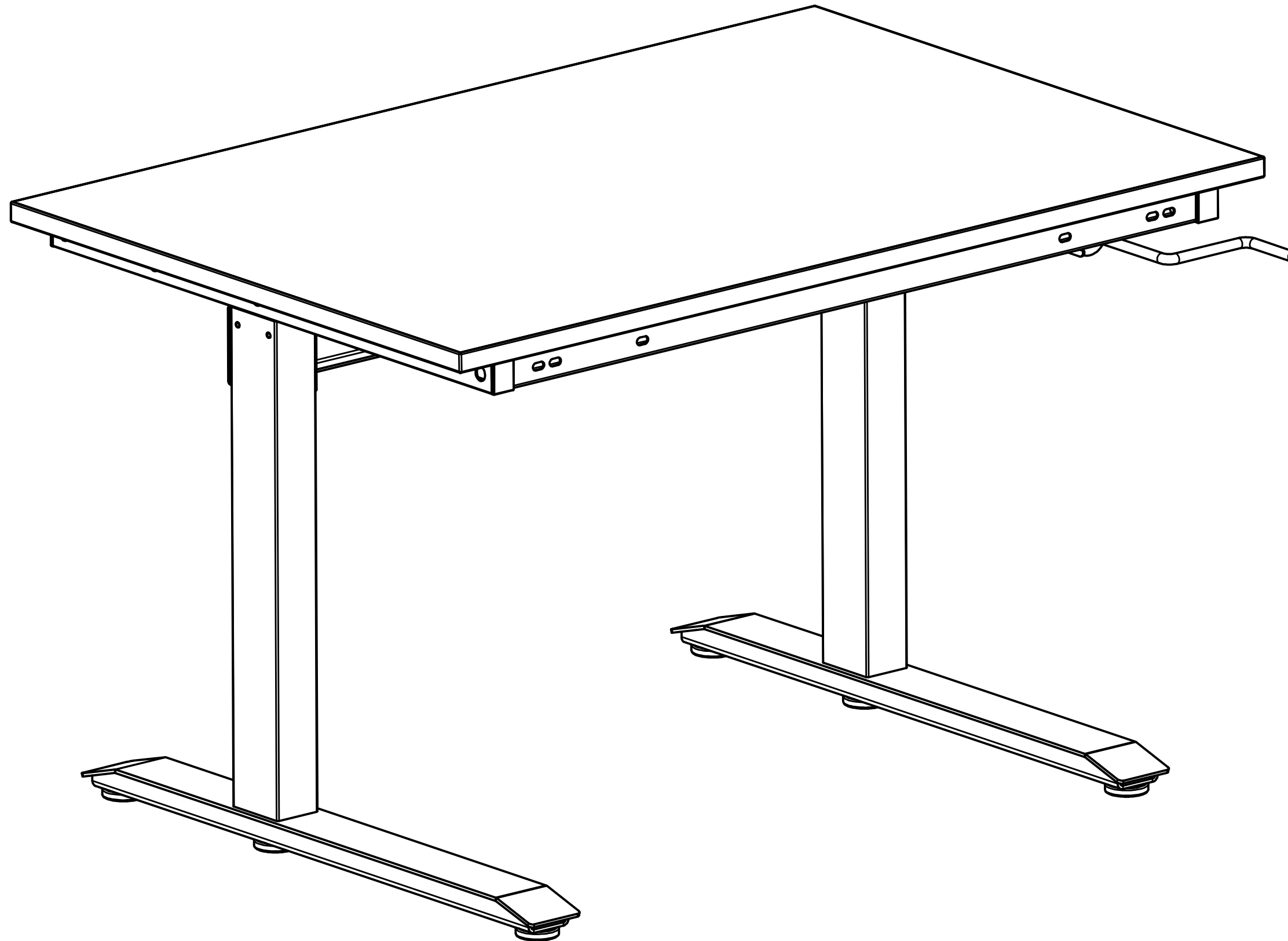

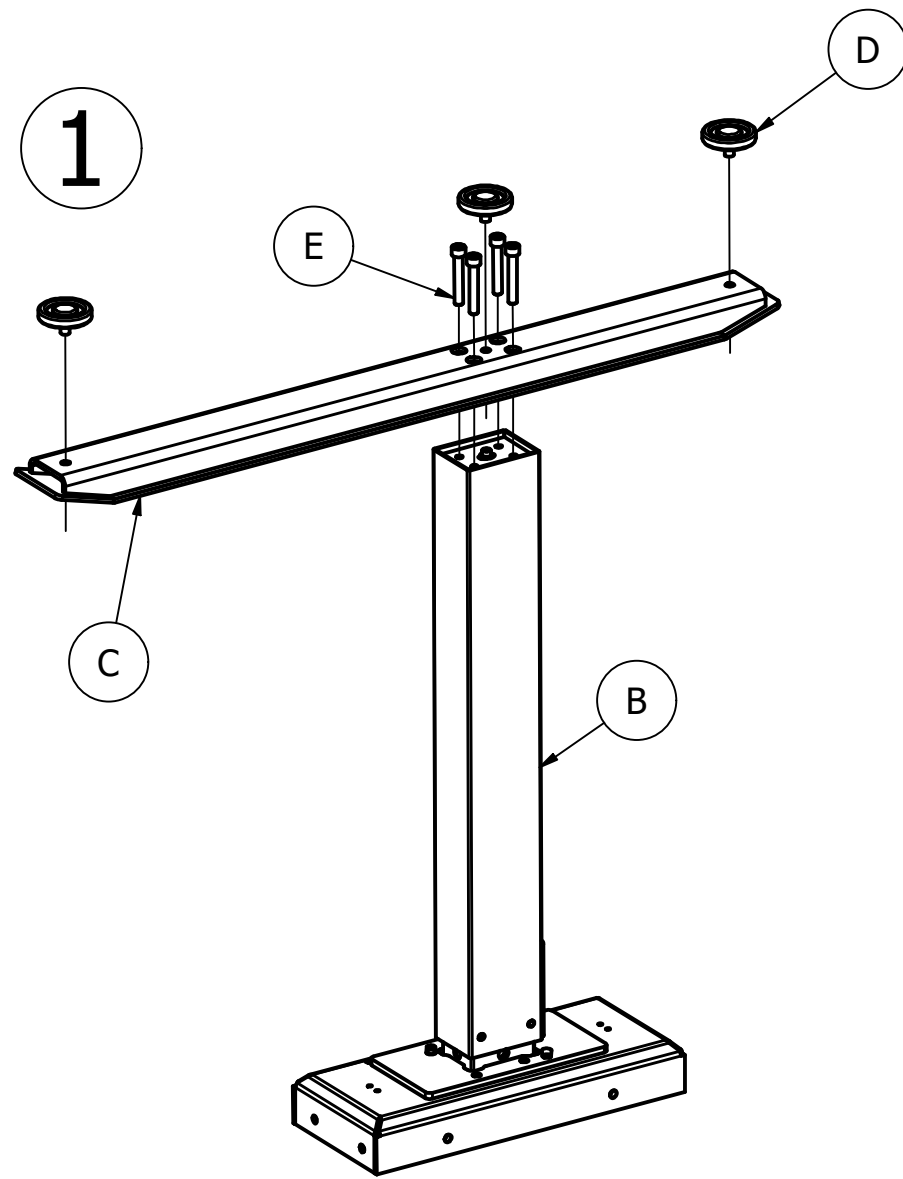
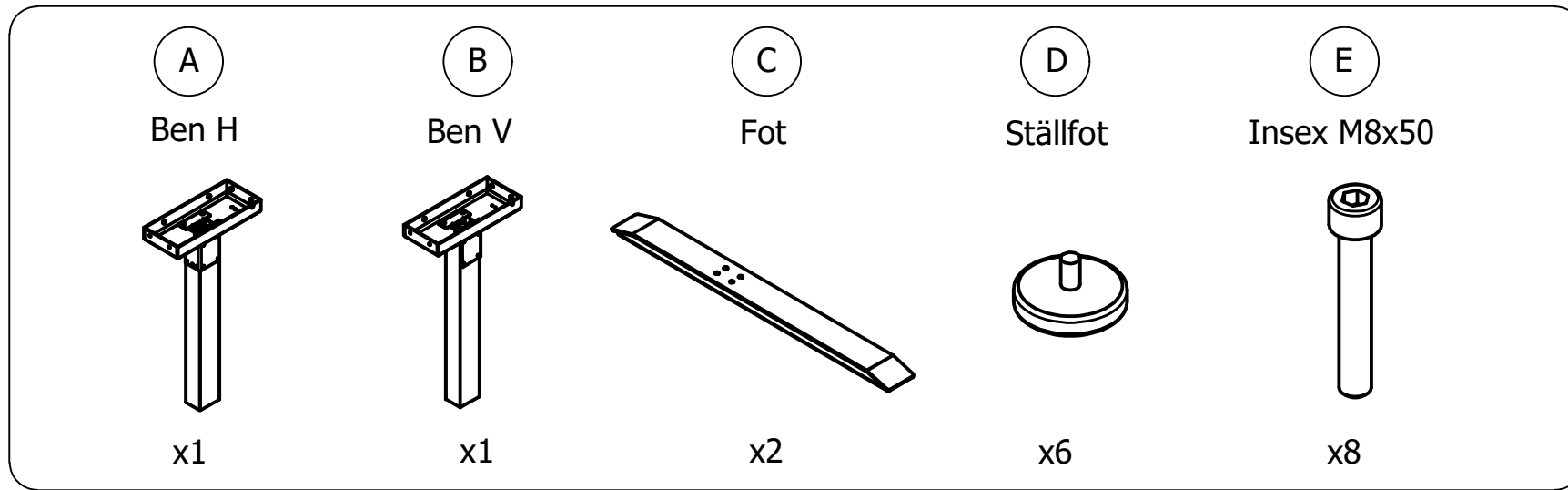

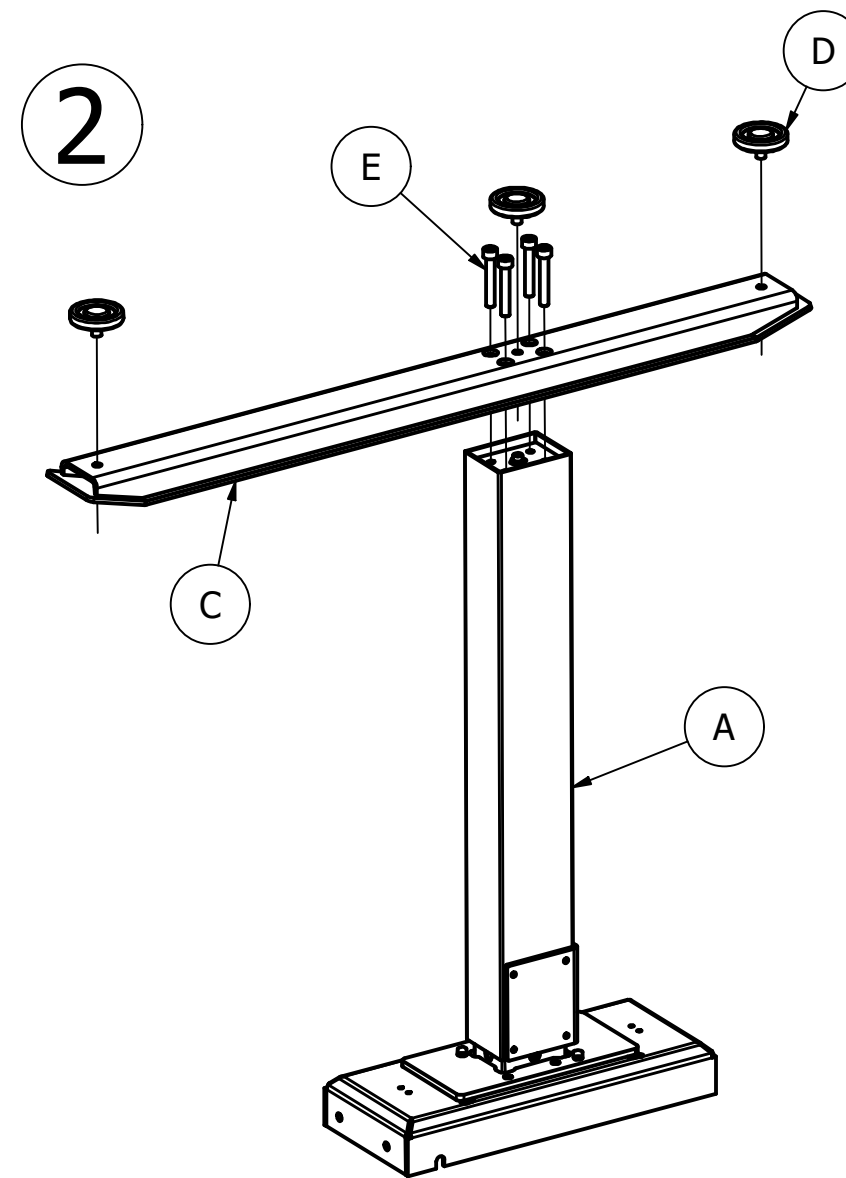

Vänster

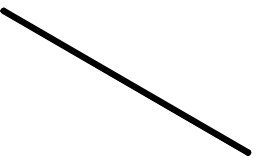
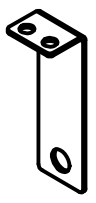
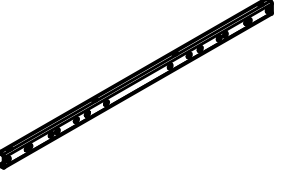
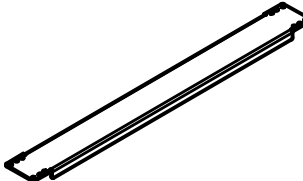
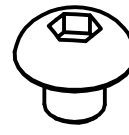
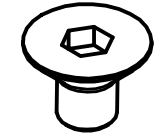

Höger

A	B	C	D	E	F	G
Stång 1020mm	Stångstyrning	Tvärprofil	Mellanstag	Rund insex M8x8	För. insex M8x12	O-ring
						
x1	x1	x1	x1	x4	x4	x2

1

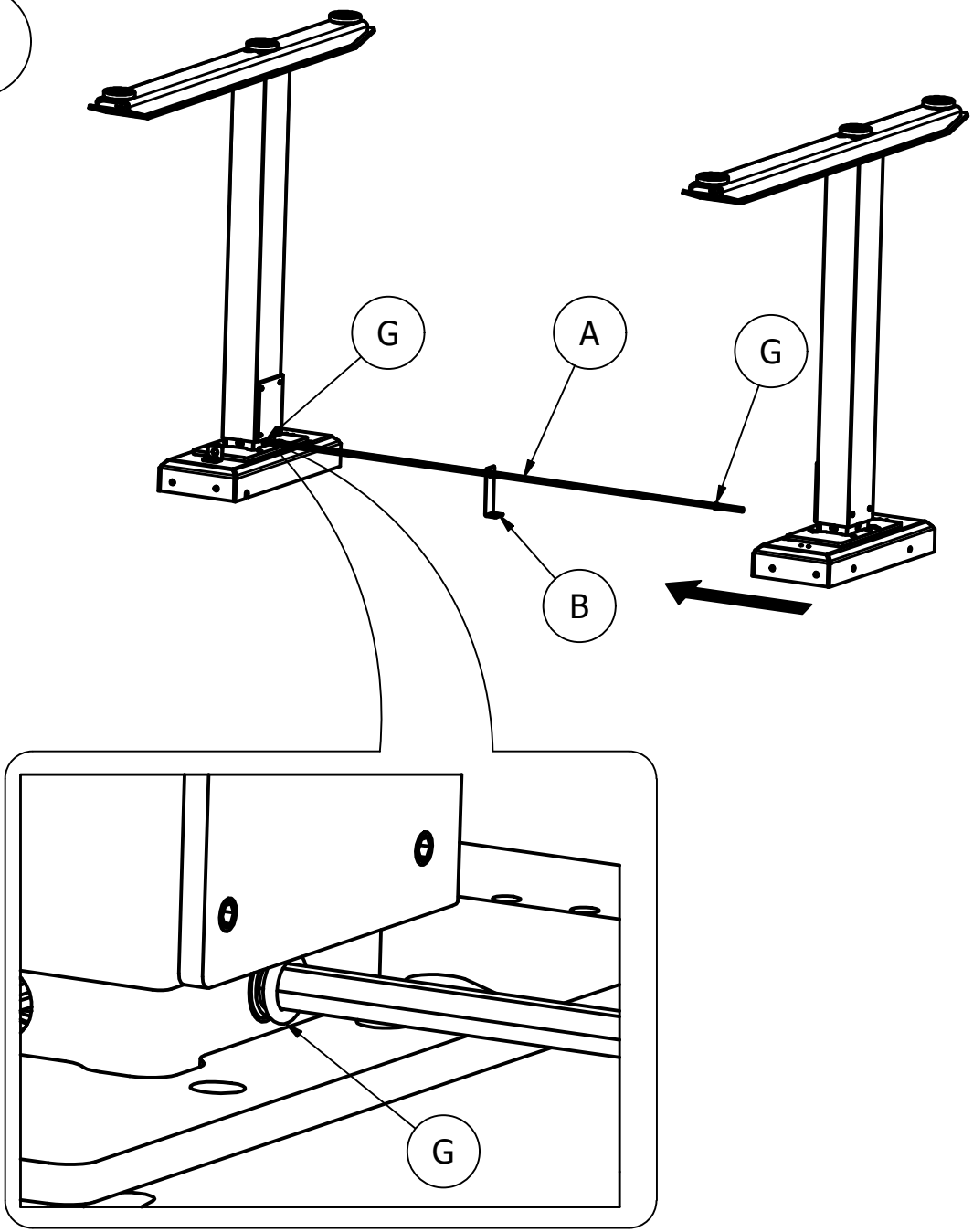

2

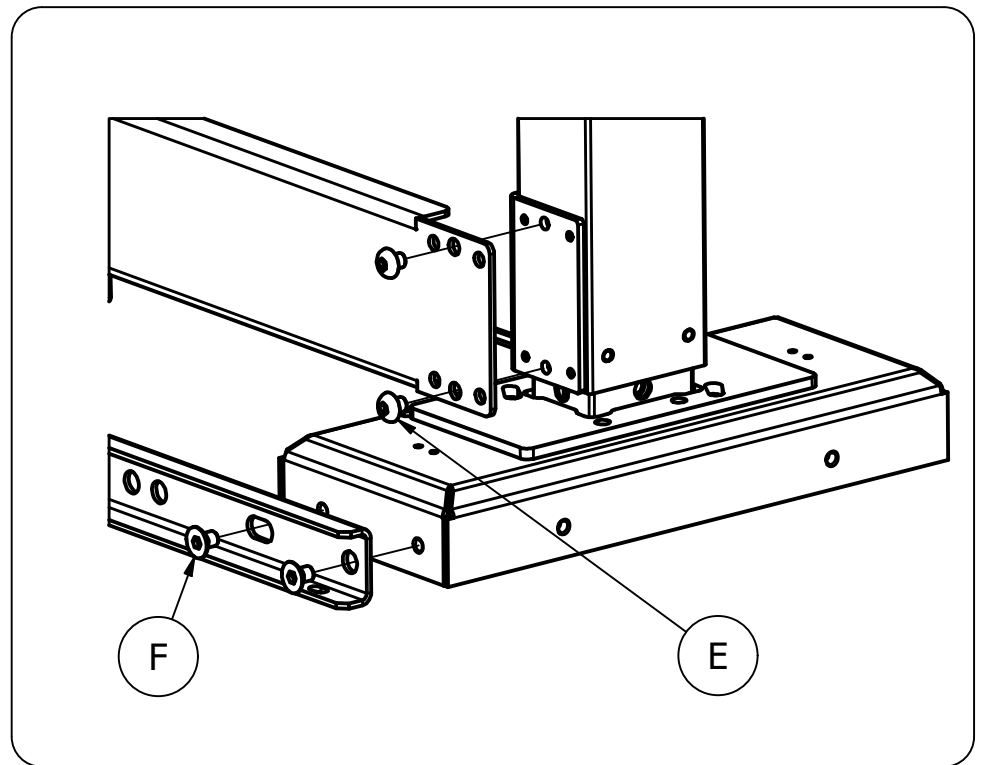
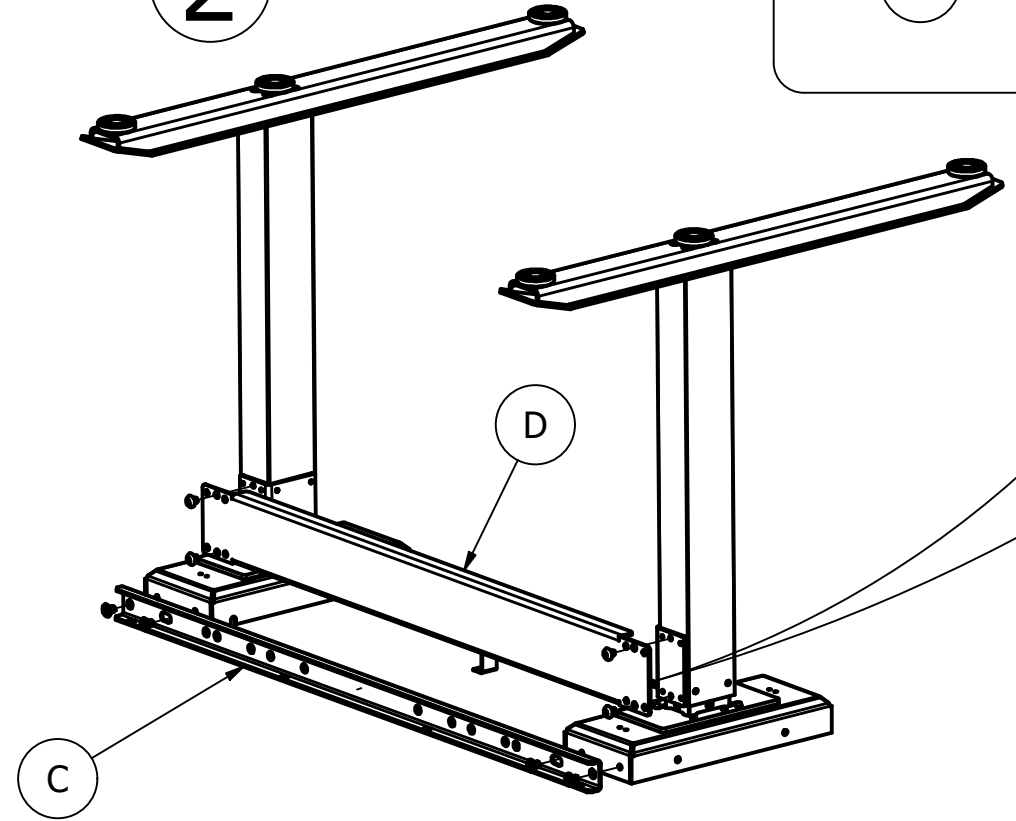

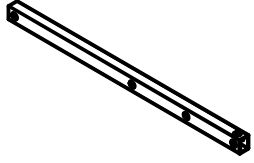
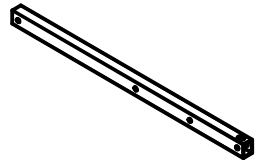
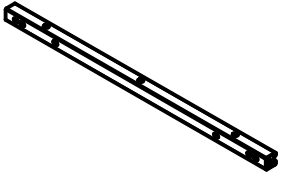
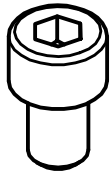
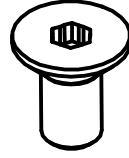
A	B	C	D	E
Ytterprofil H	Ytterprofil V	C-profil	Insex M8x20	För. insex M8x12
				
x1	x1	x2	x4	x4

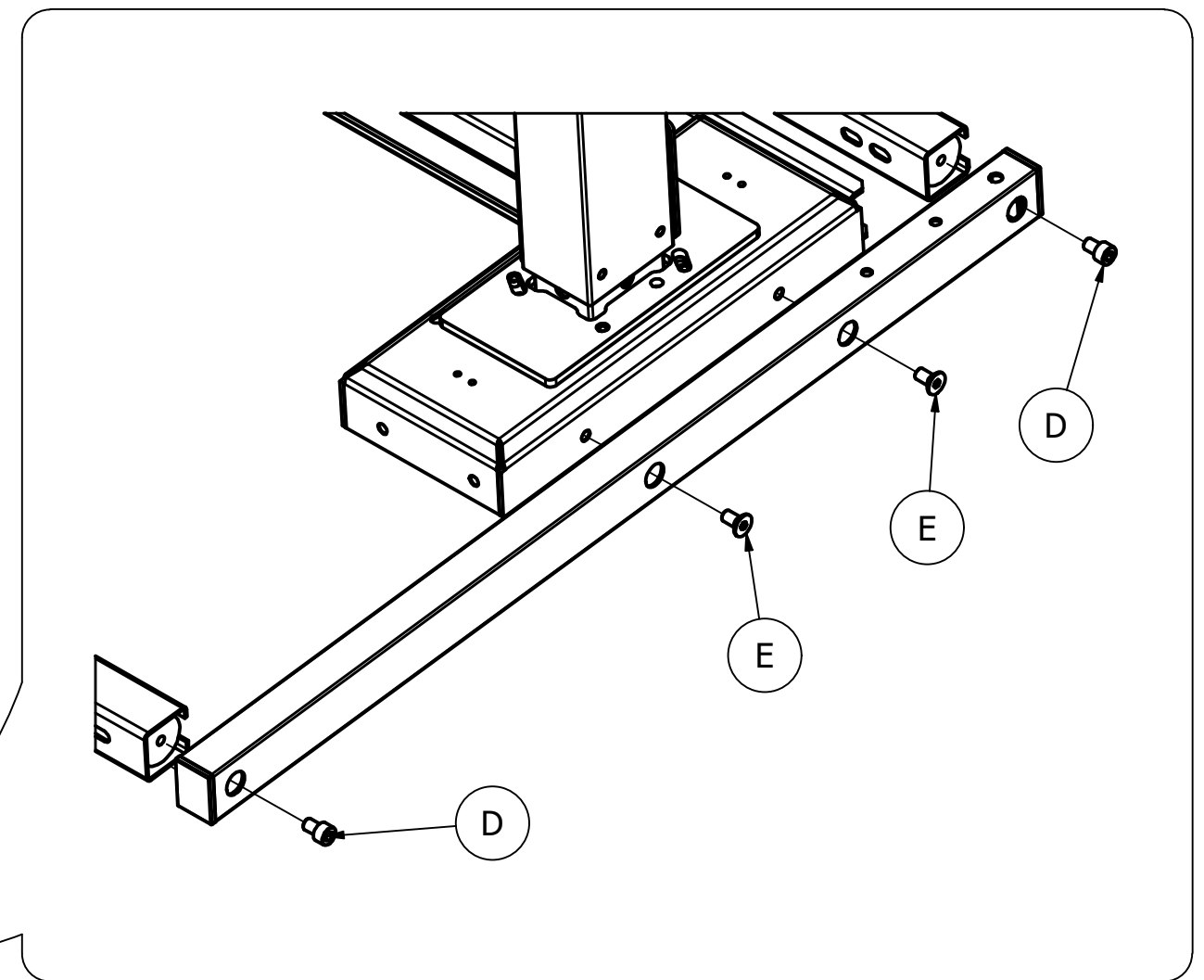
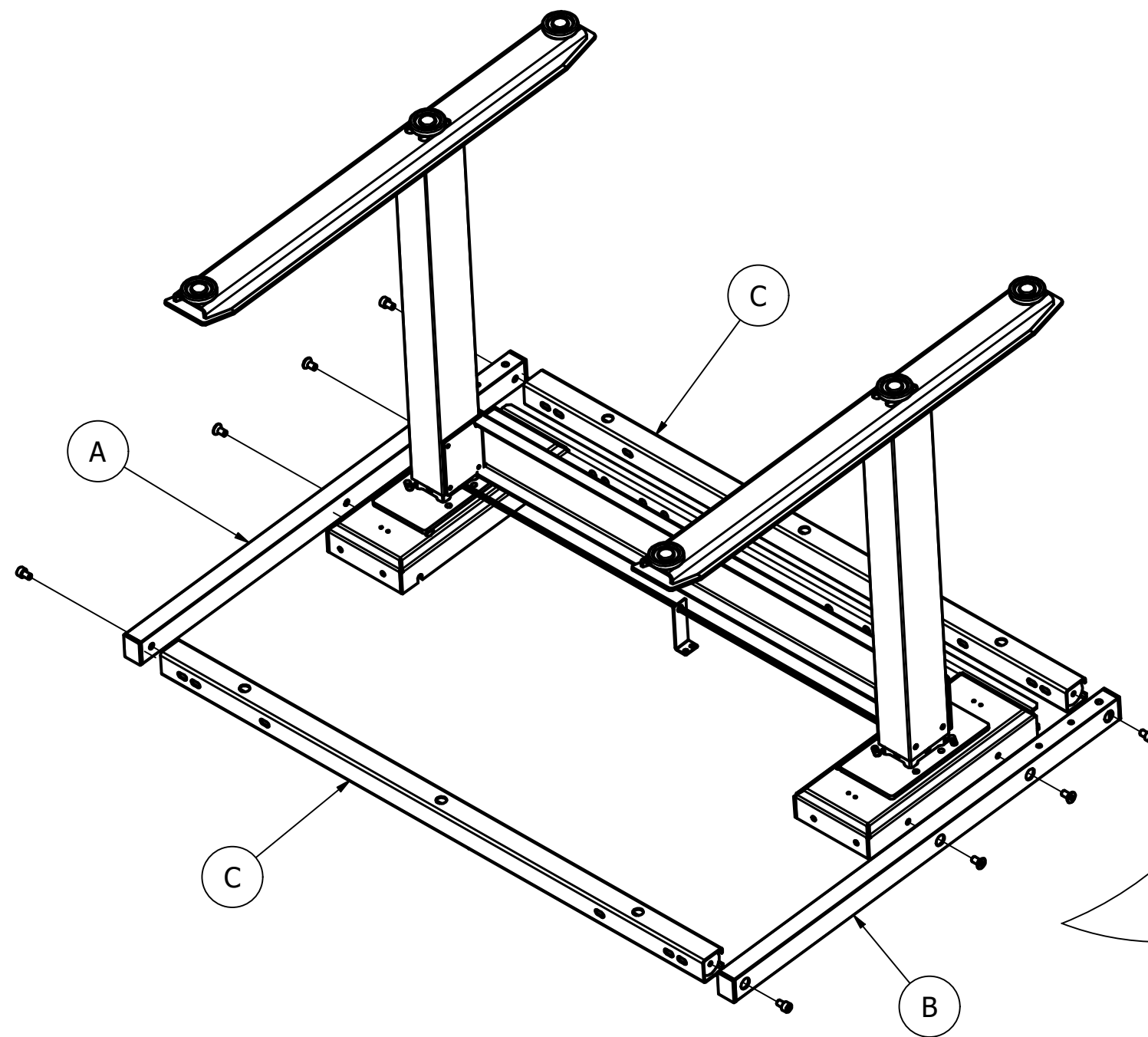

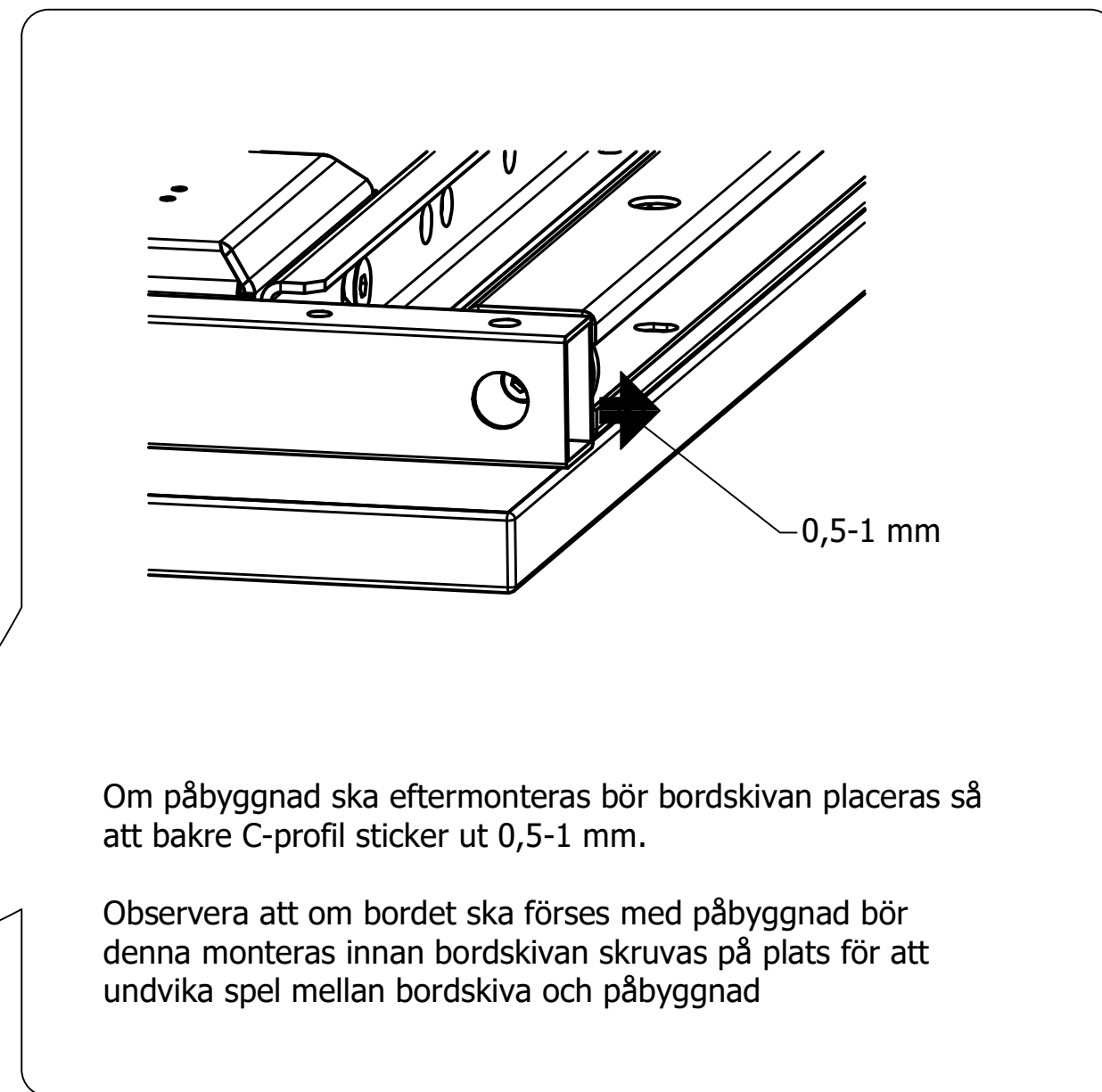
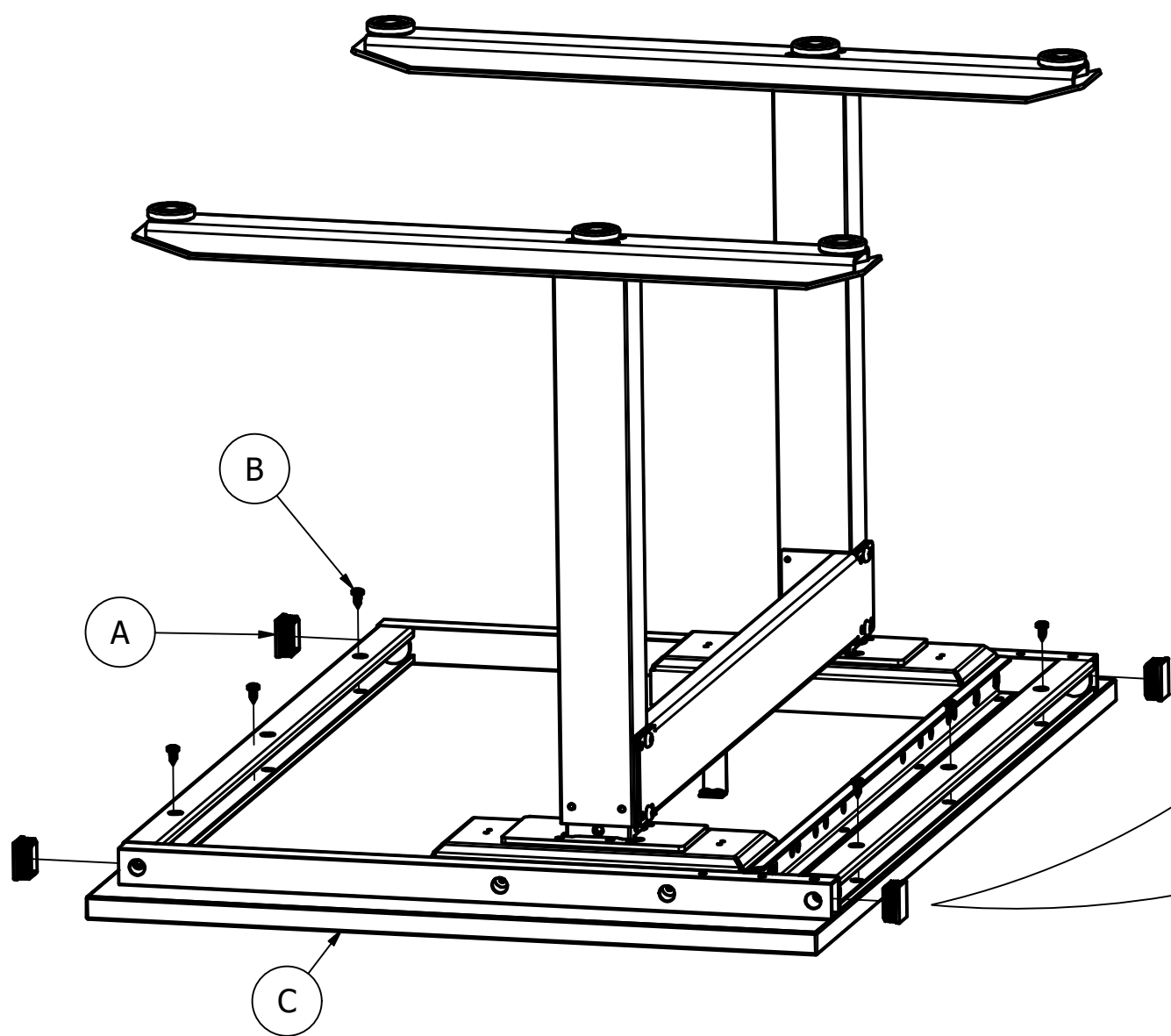
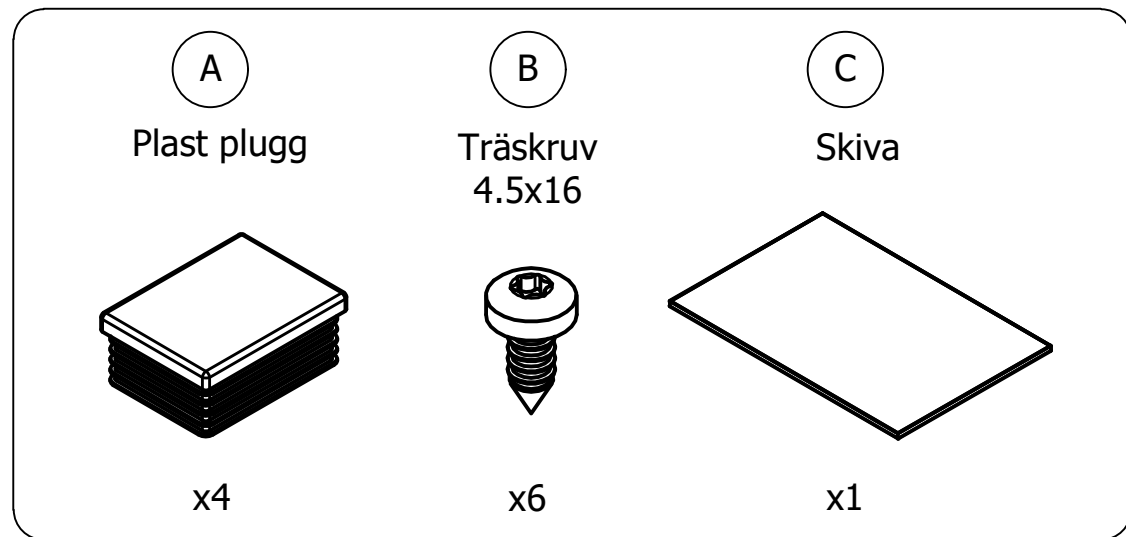

A

Träskruv
4.5x16



x2

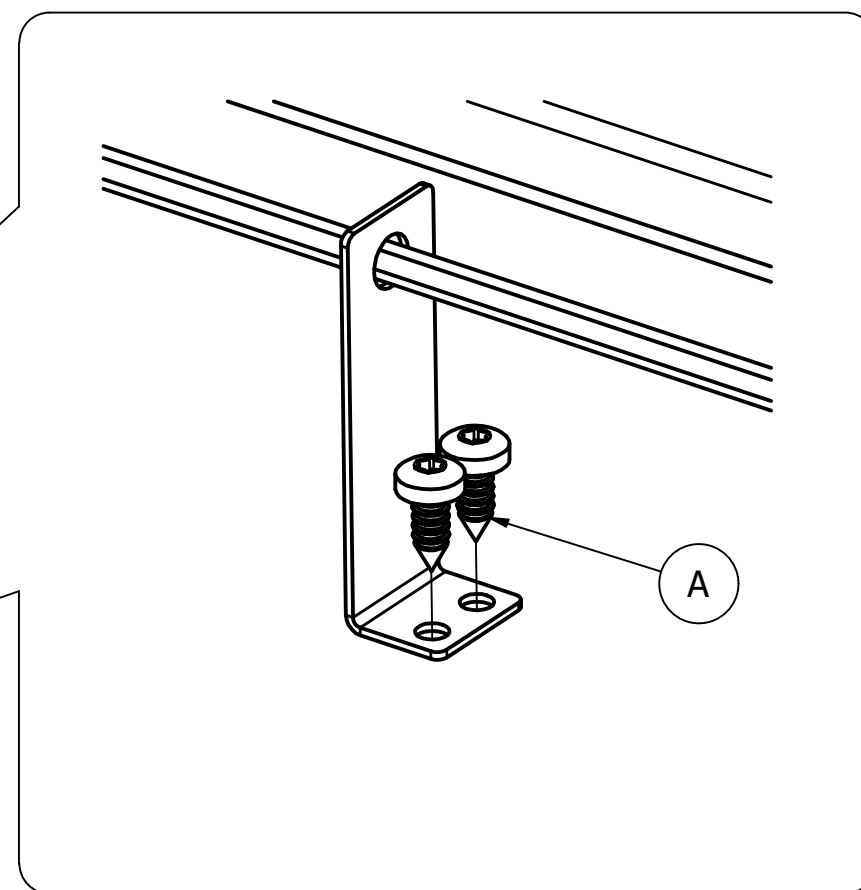
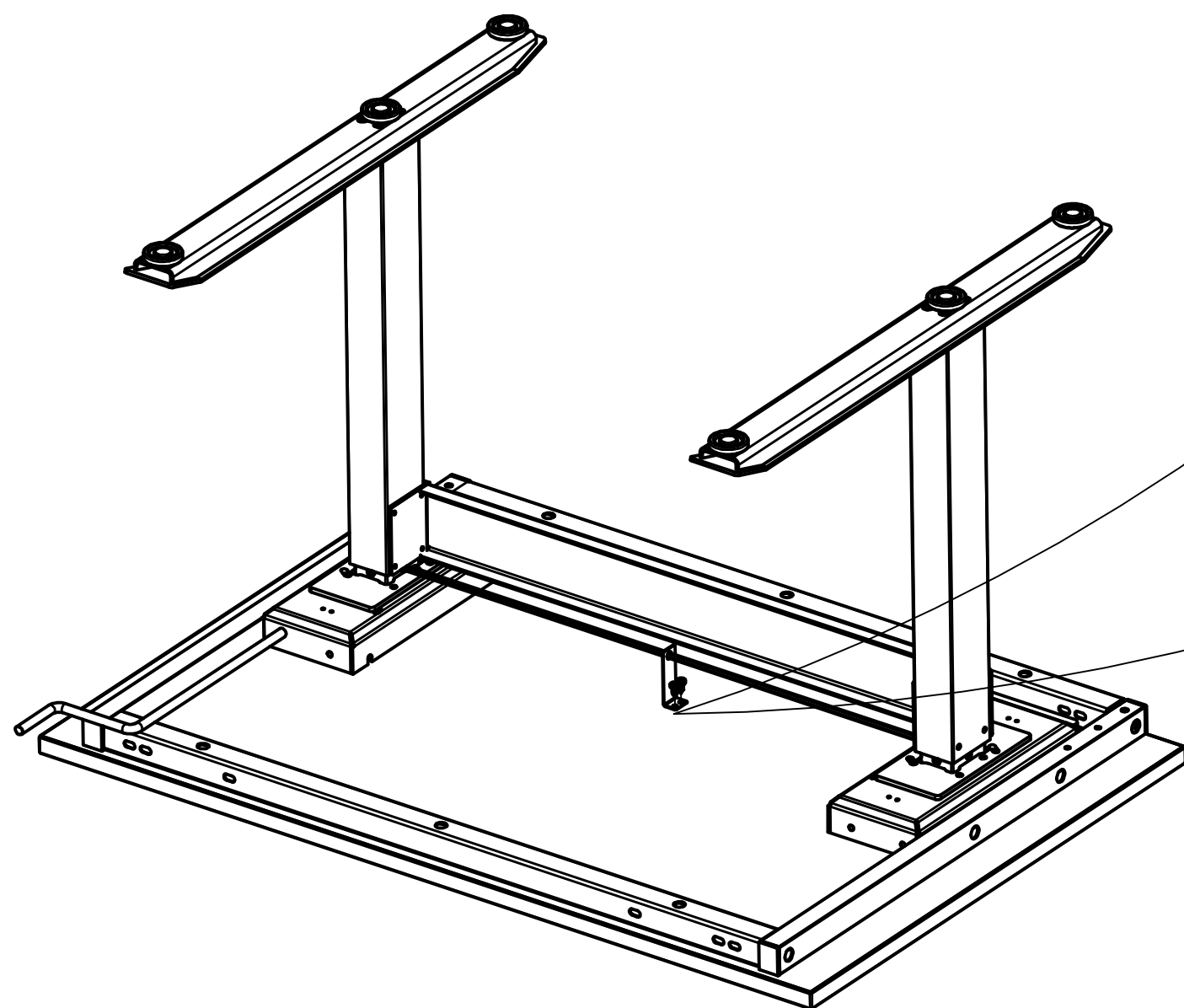

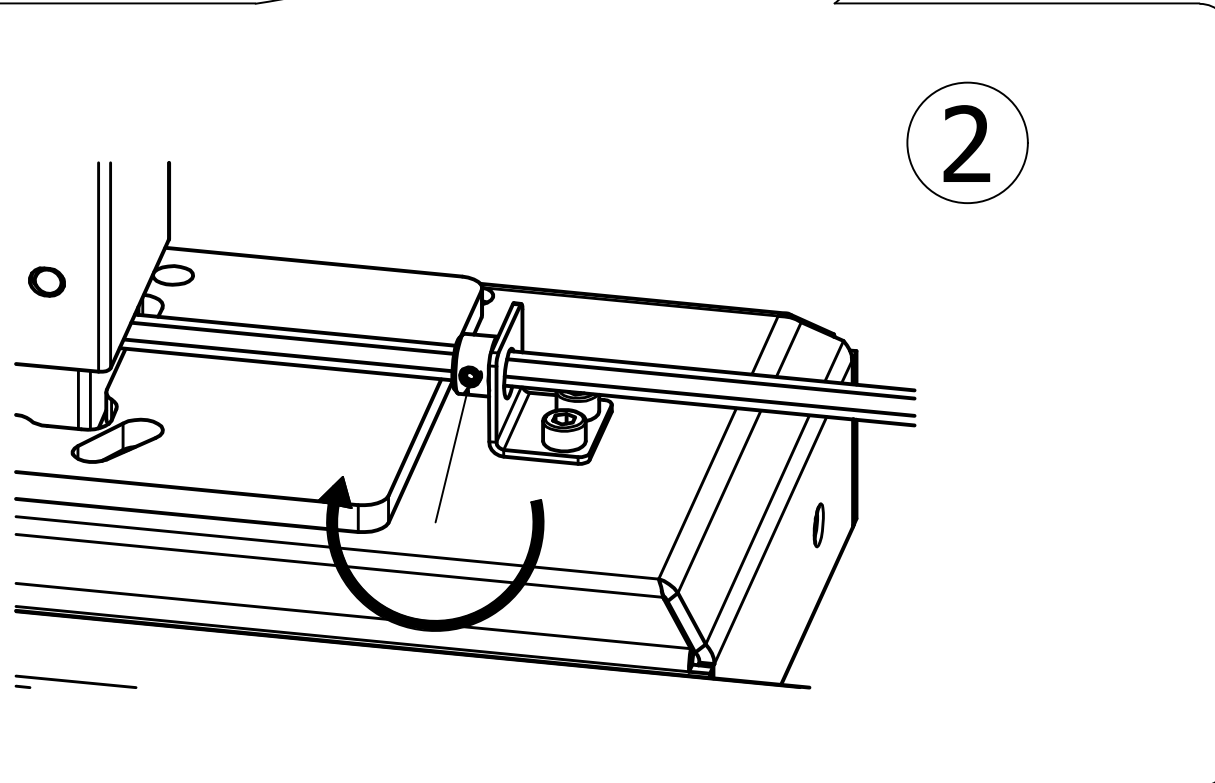
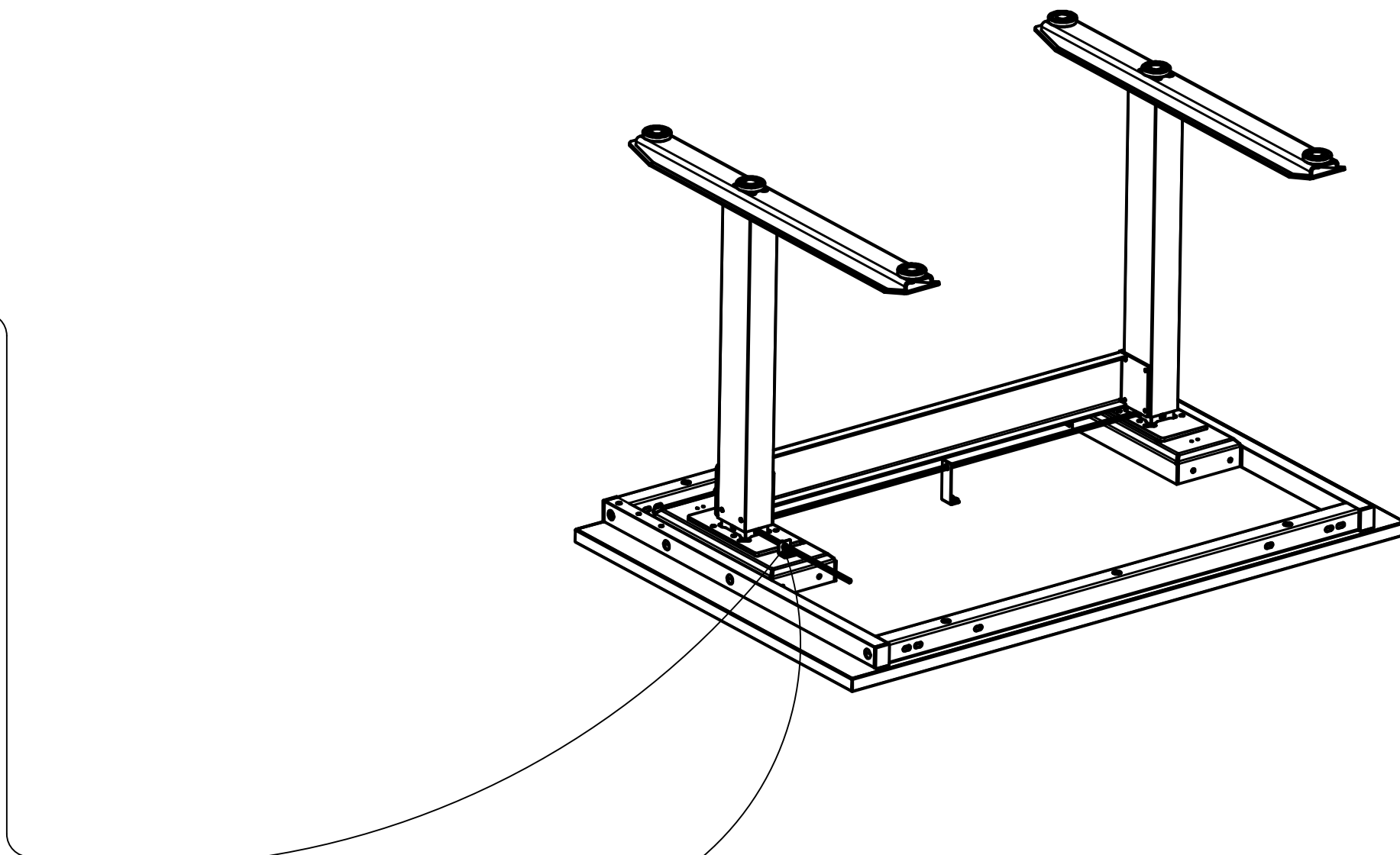
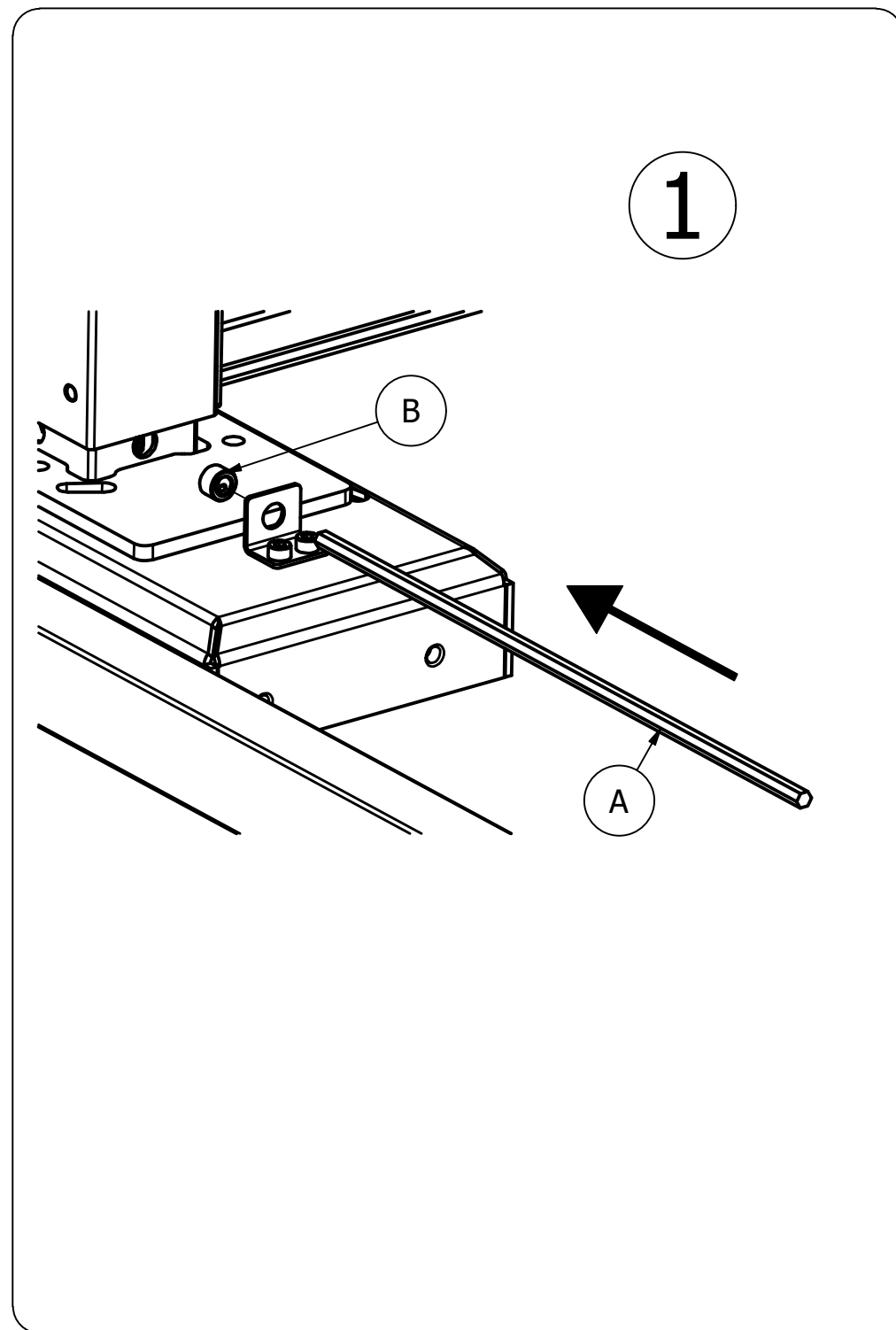
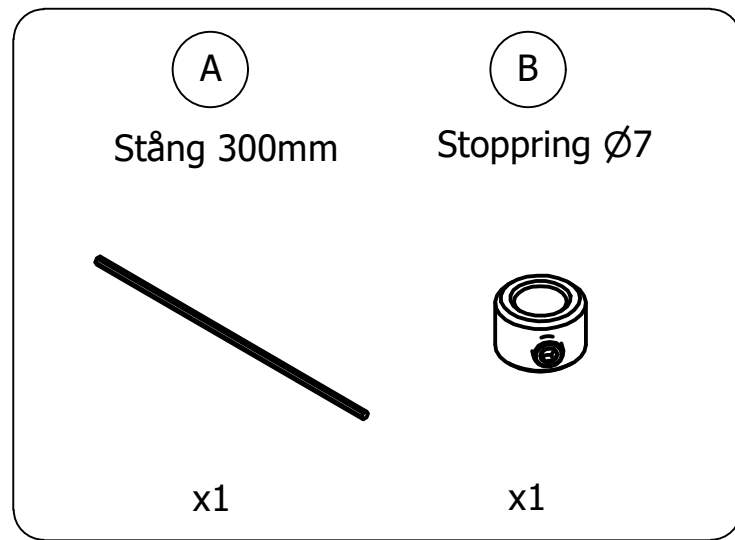

A

Fäste vev

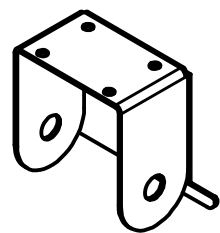

x1

B

Träskruv
4.5x16



x4

1

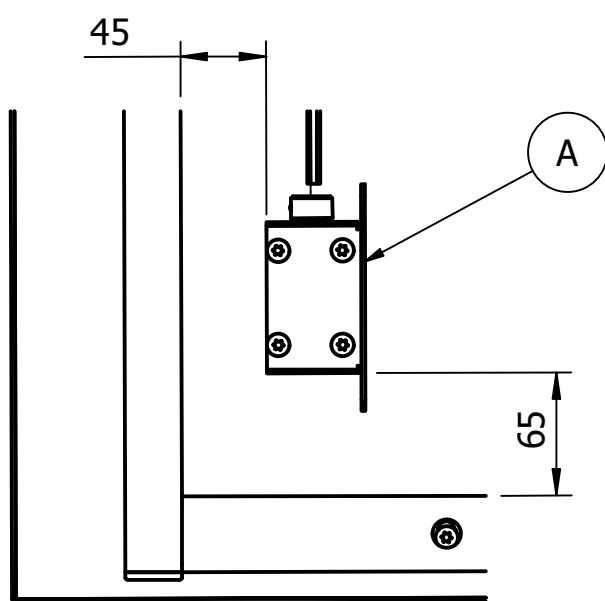

2

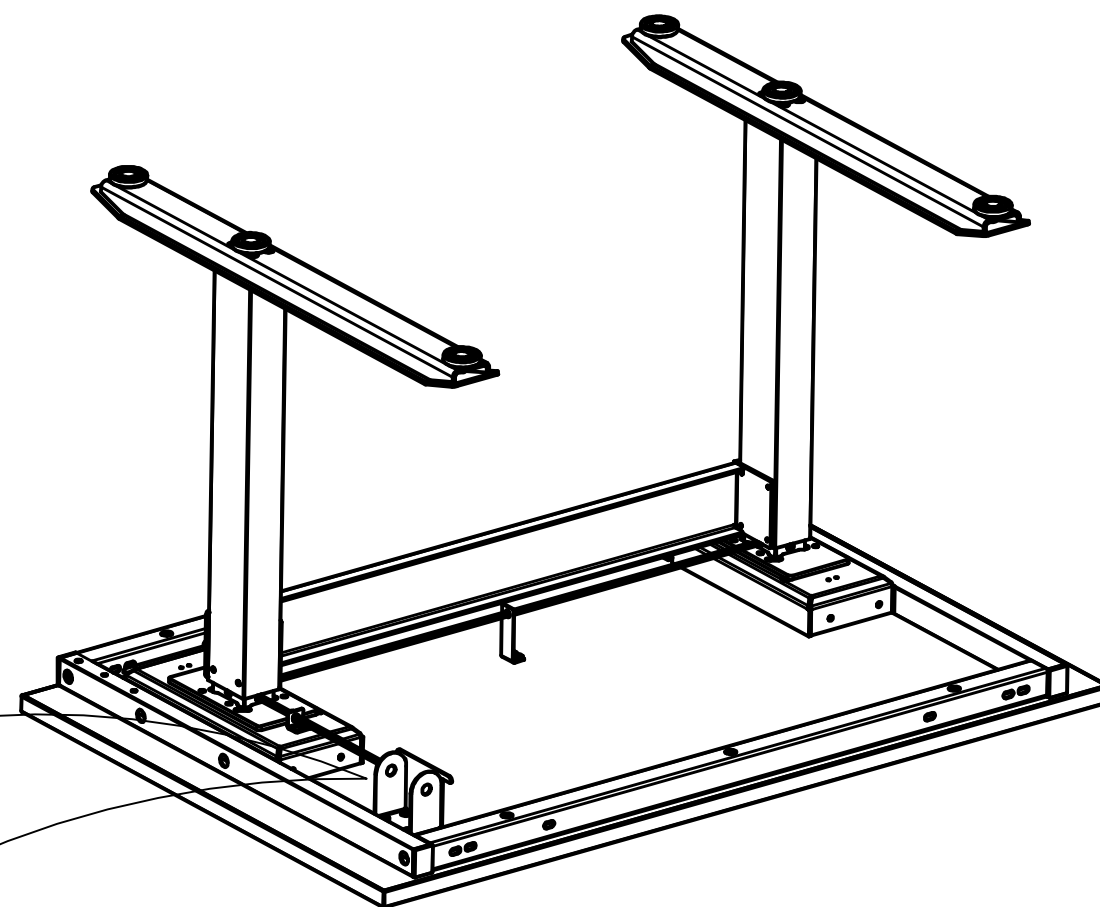
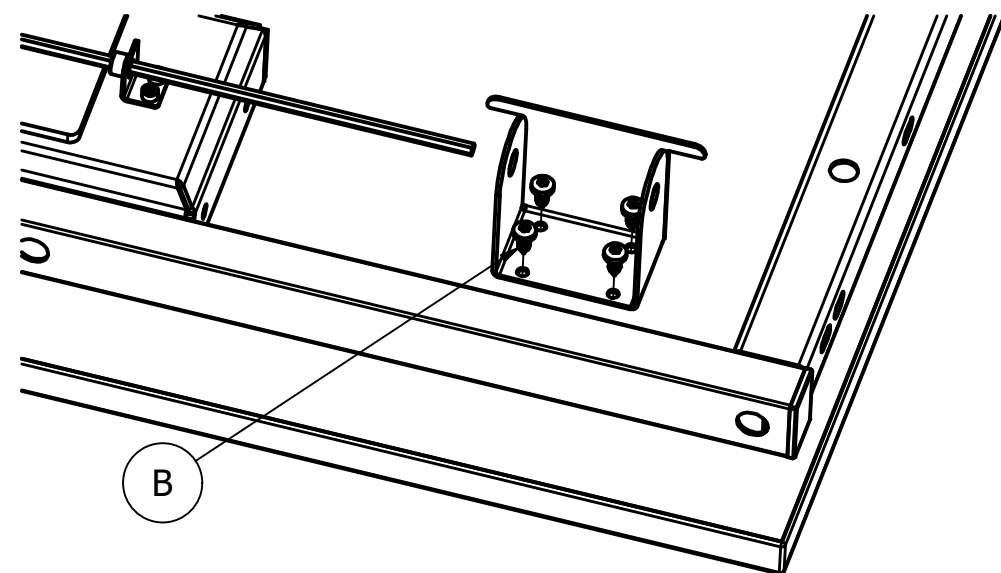

A
Vev
x1

B
Stoppning $\varnothing 12$
x1

